

5 Planning

5.1 Information for planning

In the planning and design phase, care must be taken regarding the functions or applications to be executed by the kinematic system. The following conditions can lead to premature wear. They necessitate shorter maintenance intervals and/or earlier exchange of components. In addition, the permissible operating parameters specified in the technical data must be taken into account and observed during planning.

- Continuous operation near temperature limits
- Continuous operation in abrasive environments
- Continuous operation close to the performance limits, e.g. high rpm of an axis
- Start of operation at maximum power from cold, e.g. after an idle period
- High duty cycle of individual axes
- Monotonous motion profiles, e.g. short, frequently recurring axis motions
- Static axis positions, e.g. continuous vertical position of a wrist axis
- External forces (process forces) acting on the robot

If one or more of these conditions are to apply during operation of the kinematic system, KUKA Service must be consulted.

If the robot reaches its corresponding operation limit or if it is operated near the limit for a period of time, the built-in monitoring functions come into effect and the robot is automatically switched off.

This protective function can limit the availability of the robot system.

5.2 Mounting base with centering

Description

Designation	Article number	Weight
Mounting base set S780	0000-327-118	approx. 58.5 kg

The mounting base with centering is used when the kinematic system is fastened to the floor, i.e. directly on a concrete foundation.

The mounting base with centering consists of:

- Bedplates
- Chemical anchors
- Fastening elements

This mounting variant requires a level and smooth surface on a concrete foundation with adequate load bearing capacity. The concrete foundation must be able to accommodate the forces occurring during operation. There must be no layers of insulation or screed between the bedplates and the concrete foundation.

The minimum dimensions must be observed.

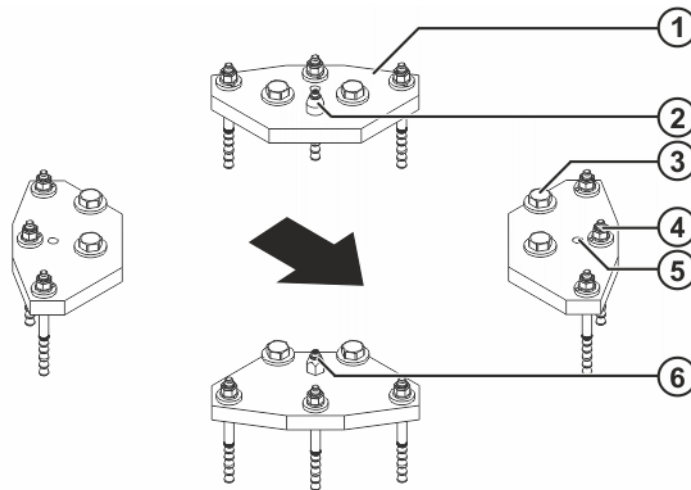

Fig. 5-1: Mounting base

- 1 Bedplate (4x)
- 2 Locating pin, cylindrical
- 3 M24x65-8.8-A2K hexagon bolt with conical spring washer (8x)
- 4 Chemical anchor (12x)
- 5 M20 tapped hole for leveling screws (4x)
- 6 Locating pin, flat-sided

Grade of concrete for foundations

When producing concrete foundations, the load-bearing capacity of the ground and the country-specific construction regulations must be observed. There must be no layers of insulation or screed between the bedplate/bedplates and the concrete foundation. The quality of the concrete must meet the requirements of the following standard:

- C20/25 according to EN 206



WARNING

Danger to life and limb due to incorrect mounting

If not mounted correctly, the kinematic system may topple over or fall down. Death, severe injury or damage to property may result.

- Only install the kinematic system using the mounting base or machine frame mounting.
- The stability must be ensured by the integrator or start-up technician.

Dimensioned drawing

The following illustration (>>> [Fig. 5-2](#)) provides all the necessary information on the mounting base, together with the required foundation data. The specified foundation dimensions refer to the safe transmission of the foundation loads into the foundation and not to the stability of the foundation.

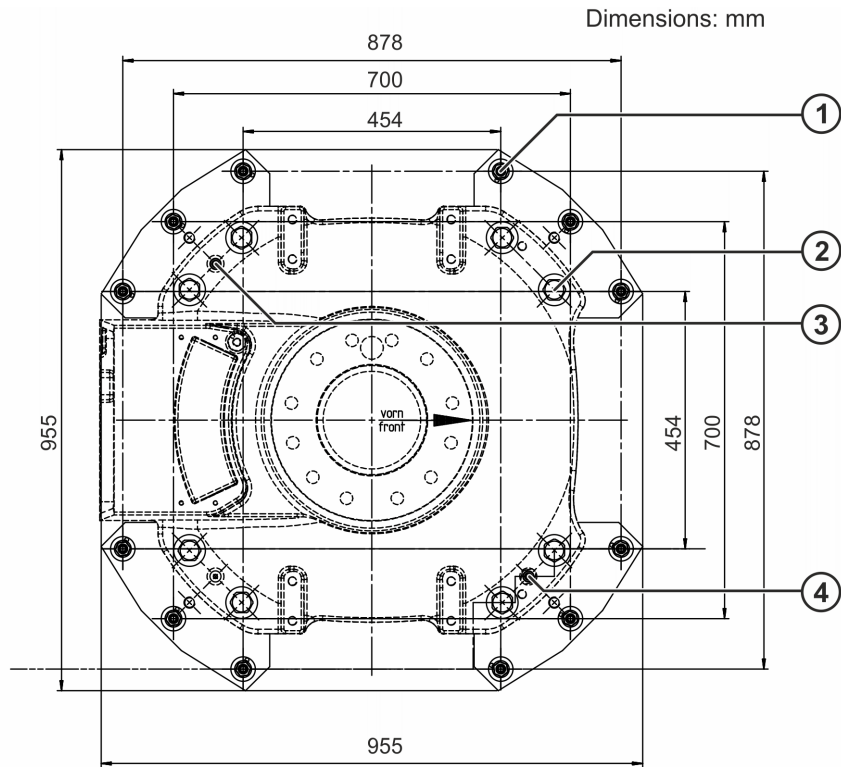

Fig. 5-2: Mounting base, dimensioned drawing

- 1 Chemical anchor (12x)
- 2 M24x65-8.8-A2K hexagon bolt (8x)
- 3 Locating pin, cylindrical
- 4 Locating pin, flat-sided

To ensure that the anchor forces are safely transmitted to the foundation, observe the dimensions for concrete foundations specified in the following illustration.

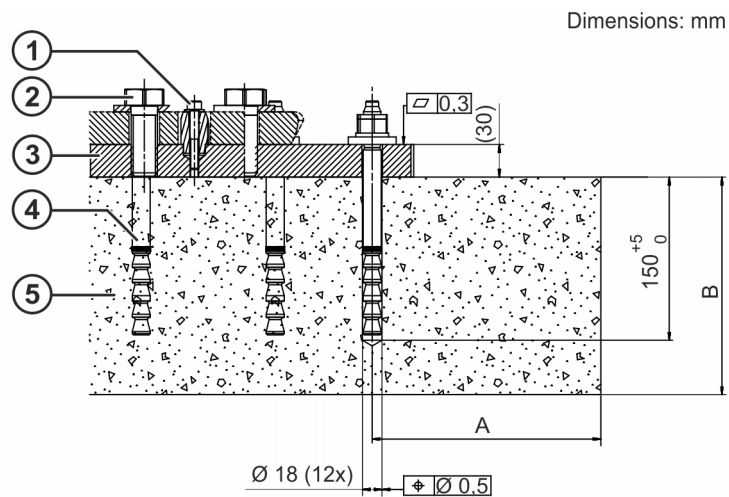

Fig. 5-3: Foundation cross-section

- 1 Locating pin
- 2 Hexagon bolt with lock washer
- 3 Bedplate
- 4 Chemical anchor
- 5 Concrete foundation

B Min. concrete thick- ness in mm	Concrete grade	A Min. distance to edge in mm
180	Without edge reinforcement	360
	With edge reinforcement $\geq \varnothing 12$	290
	With edge reinforcement $\geq \varnothing 12$ and stirrup re- inforcement at a distance of ≤ 100 mm	245
200	Without edge reinforcement	340
	With edge reinforcement $\geq \varnothing 12$	275
	With edge reinforcement $\geq \varnothing 12$ and stirrup re- inforcement at a distance of ≤ 100 mm	230
250	Without edge reinforcement	300
	With edge reinforcement $\geq \varnothing 12$	240
	With edge reinforcement $\geq \varnothing 12$ and stirrup re- inforcement at a distance of ≤ 100 mm	200

5.3 Mounting base 150 mm (optional)

Description

Designation	Article number	Weight
Mounting base S780	0000-338-338	approx. 261 kg

The mounting base with centering is used when the kinematic system is fastened to the floor, i.e. directly on a concrete foundation.

The mounting base with centering consists of:

- Bedplate
- Chemical anchors
- Fastening elements

This mounting variant requires a level and smooth surface on a concrete foundation with adequate load bearing capacity. The concrete foundation must be able to accommodate the forces occurring during operation. There must be no layers of insulation or screed between the bedplate and the concrete foundation.

The minimum dimensions must be observed.